

**MA-340** is an advanced, multi-featured analog addressable multisensor smoke and heat detector designed for the MA analog addressable fire system family. Like the MA 320 smoke detector smoke detector, it quickly detects fast, clean burning and smoldering fires while its heat sensors provide an additional layer of protection as they include an alarm threshold which improves the rejection of many factors that cause common false alarms with an additional alarm raised when temperature reaches 60°C or more.



---

### System Functionality:

- Operates on low current, has built-in short circuit isolators
- Advanced LED design with a 360° view indicating the status of the detector;
- Illuminates continuously during fire conditions
- Flashes to confirm communication with the control panel
- Soft addressed
- Single address

---

### Features & Benefits:

- Quick and simple to install, operate and service
- Simple clean design
- Cable entry from rear or side of base
- Removable detector chamber
- Wiring via common mounting base
- Drift compensation
- Positive lock indicator to ensure detector is properly installed on base
- Two-second start-up and reset time

**Technical Specifications:**

<b>Code</b>	<b>MA-340</b>
<b>Description</b>	Analog Addressable Multisensor Smoke and Heat Detector, UQGS.S36306
<b>Standards</b>	UL268 6th edition, EN54-3, SII1220, TR TC EAC 043-2017

**Specification**

<b>Operating Voltage</b>	18V dc to 30V dc
<b>Standby Current</b>	220µA (max)
<b>Alarm Current</b>	5mA (max)
<b>Addressing Mode</b>	Auto address
<b>Mounting Position</b>	Ceiling in open areas
<b>Mounting Options</b>	Addressable MA-300 detector base
	Addressable MA-BS sounder base
	Addressable MA-BSH sounder beacon base
<b>Area Coverage</b>	50m <sup>2</sup> or 100m <sup>2</sup> (subject to local standard)
<b>System Wiring</b>	Min. 1.5mm, 2 core loop or spur

**Heat Class**

<b>Rate of Rise</b>	A1R
---------------------	-----

**Alarm Temperature (Static)**

<b>AIR</b>	60°C
<b>Indication</b>	360° visibility light pipe

**Environmental**

<b>Environmental Operating Temperature</b>	0 - 49°C
<b>Humidity (Non-Condensing)</b>	0 - 93% RH

**Physical**

<b>Construction</b>	PC/ABS
<b>Colour</b>	White
<b>Weight</b>	0.120 kg

**Compatibility**

<b>Suitable for Use With</b>	MTech MA Analog Addressable Fire System
------------------------------	---

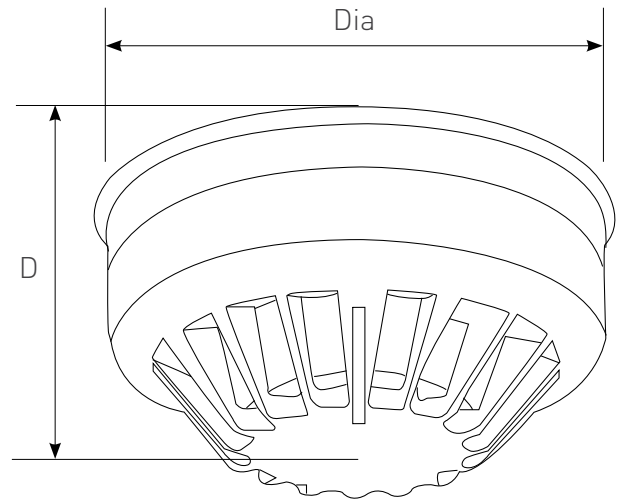

**Dimensions:**

**Dia.** 101 mm | **D.** 43 mm | **D (Incl. Base).** 55 mm



**Order Code:**

MA-340