

# MB-220 | Conventional Detectors

**MB-220** is a conventional two-wire optical (photoelectric) smoke detector designed for MTech's MB series of fire system. It provides the fastest response to slow burning or smoldering fires that cause large amounts of visible smoke.



## System Functionality:

- Operates on low current
- 360° view, red LED indicates alarm on

## Features & Benefits:

- Quick and simple to install, operate and service
- Removable detector chamber for cleaning
- Simple clean design
- Maintenance trouble notification
- Removable detector chamber
- Wiring via common mounting base
- Drift compensation
- Lock which opens only with special tool, to prevent unauthorized sensor removal

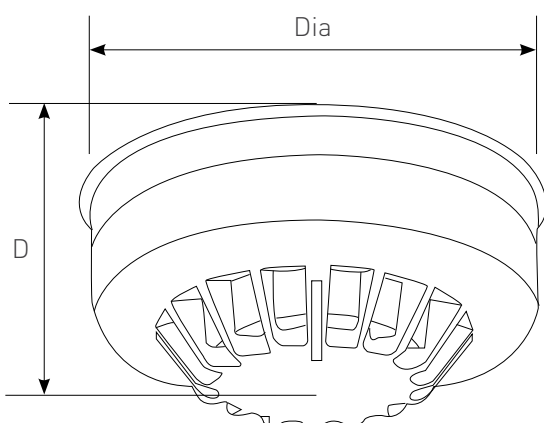

## Dimensions:

**Dia.** 101 mm | **D.** 33 mm | **D (Incl. Base).** 45 mm

Order Code:

MB-220

## Technical Specifications:

Code	MB-220
Description	Conventional Optical Smoke Detector, UROX.S36306
Standards	UL268 6th Edition, EN54-7, SII1220, TR TC EAC 043-2017

### Specification

Operating Voltage	15V dc to 30V dc
Voltage Waveform	Filtered DC, ± 1V max ripple at 120Hz
Standby Current (Average)	95µA
Surge Current (Max)	340µA
Alarm Current (Max)	Must be limited externally to 40mA
Start-Up Time	20 seconds
Sensitivity	2.55 ± 0.33% /ft
Sensitivity Checker	Use no climb model TruTest (UL Listed)
Reset Time (Max)	2 seconds
Mounting Position	Ceiling at walls in open areas
Mounting Options	Conventional MB-300 detector base
Area Coverage	100m <sup>2</sup> (subject to local standard)
Indication	360° visibility light pipe

### Environmental

Environmental Operating Temperature	0 - 49°C
Humidity (Non-Condensing)	0 - 93% RH

### Physical

Construction	PC/ABS
Color	White
Weight	0.120 kg

### Compatibility

Suitable for Use With	MTech Conventional System
-----------------------	---------------------------